

TECH TIP

Fan Clutch Bolts for 1989 – 1991 GM Light Truck

There have been reports of an alleged application problem with two fan clutches, part numbers 36956 and 36992. The reports are of either incorrect size bolts and or bolt holes where the fan blade attaches to the fan clutch.

Application- Fan clutches for 1989-1991 GM light trucks (C/K and R/V series). During these model years, the original equipment manufacturer (OEM) used both a clockwise and a counter-clockwise rotation clutch. The OEM clockwise clutch utilizes 5/16-inch bolts while the OEM counter-clockwise clutch utilizes 10-mm bolts. Factory Air by Four Seasons fan clutches are based on OEM specs.

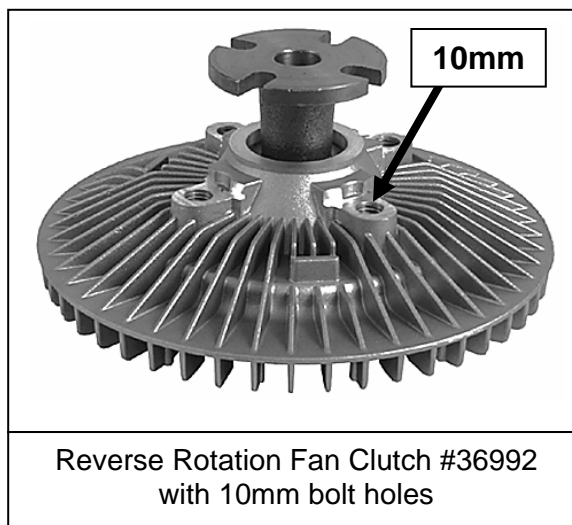
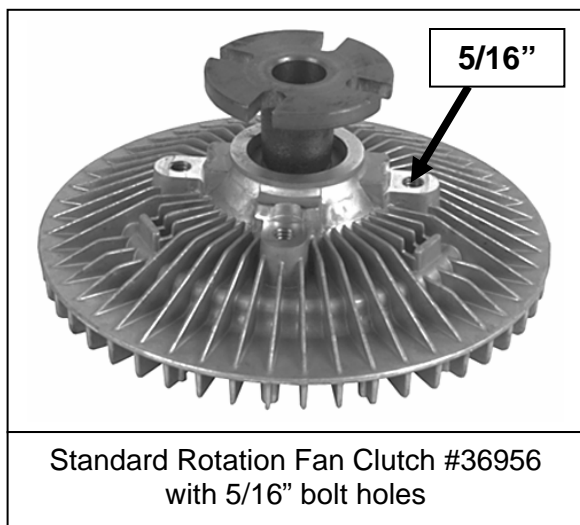

Be very careful to match the correct fan clutch to the correct application.

Many aftermarket clutch manufacturers have chosen to produce fan clutches with the 5/16" bolt hole for both standard and reverse rotation clutches. If the fan clutch has previously been replaced with an aftermarket unit, the OEM bolts may have been replaced with smaller (5/16") aftermarket supplied bolts. If this is the case, the Factory Air by Four Seasons replacement fan clutch will require the use OEM bolts. If the customer retained the original OEM 10-mm bolts, those can be used. Otherwise the four OEM 10-mm bolts can be purchased through any local GM Dealership as GM part # 11516869. If OE bolts are unavailable, they can be fabricated from existing stock to the following specifications: Grade 5 Hex Head - 10mm x 1.5 x 13mm. Most bolts, close to this spec, are available in a 20mm length and will need to be trimmed down to 13mm. Be sure that the threads are clean with the use of a dye (run the dye toward the hex end of the bolt prior to trimming the length). Final installation will require the use of a washer and loctite.

Remember – Choose the correct clutch, either clockwise (standard) rotation or counter-clockwise (reverse) rotation. Never make modifications to either the clutch or the fan blade.