

TECH TIP

Testing Ford's IRCM / CCRM for No Clutch Operation

Since 1986, Ford has used, on several models, an Integrated Relay Control Module (IRCM) to operate the fuel pump, engine cooling fan and compressor clutch. During the early 1990's, the name was changed to Constant Control Relay Module (CCRM). The module has a 24-pin connector and is normally mounted on the radiator support. A common complaint on vehicles with this module is "No clutch operation." This condition can result from low voltage, poor ground, clutch problems, bad IRCM/CCRM, or a problem with engine operation. A simple test of the IRCM/CCRM can help isolate the cause of the complaint.

Using a digital voltmeter connected to ground, test for proper voltages at terminals 21, 22 and 23:

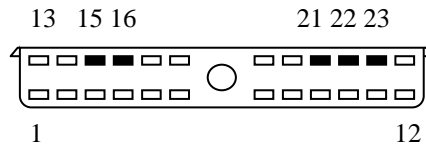

21— Battery voltage: When the driver selects A/C, power flows through the pressure switch(es) to both the powertrain control module (PCM) and the IRCM. If there is low or no voltage, check the fuse, driver switch and pressure switch(es).

22 — 6 to 7 volts: When the PCM receives an A/C request, it sends a trigger voltage to the A/C relay for clutch operation. If there is no signal (0 volt), then the PCM has detected a problem with engine operation and will not allow the clutch to engage. Check the PCM for codes and other engine performance concerns.

23 — Battery voltage: With the A/C relay triggered, voltage flows from this terminal to the clutch. If the clutch does not engage, check the clutch air gap, coil resistance and ground circuit. If there is low or no voltage, replace the IRCM/CCRM.

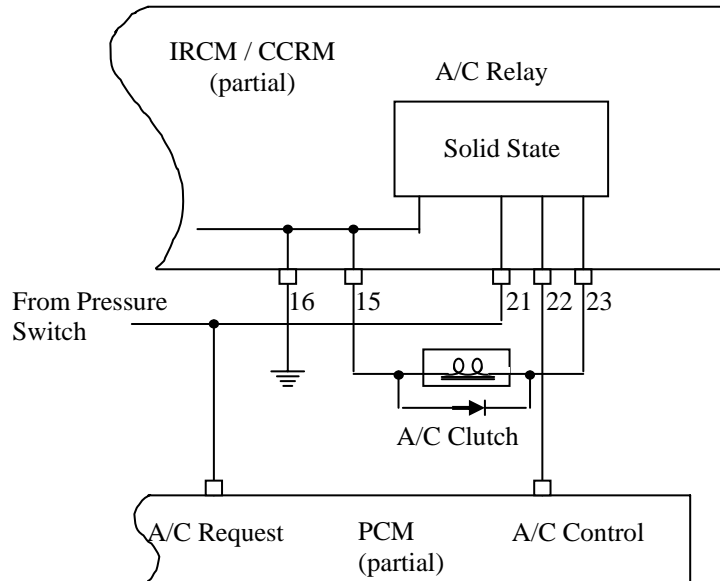

Note: This test does not apply to '96 and newer Escorts or '98 and newer Mustangs. The CCRM on these models operate differently.