

TECH TIP

BLOWER MOTOR HUMMING NOISE

Customers with late model Cadillac Deville and Seville may experience a humming noise in the passenger compartment when the heater is on high and the blower is set on a medium to high speed.

GM has determined that the most likely cause of the humming noise is from the positioning of the blower motor within the HVAC housing, causing a restriction of the incoming airflow. (GM tsb 03-01-37-001)

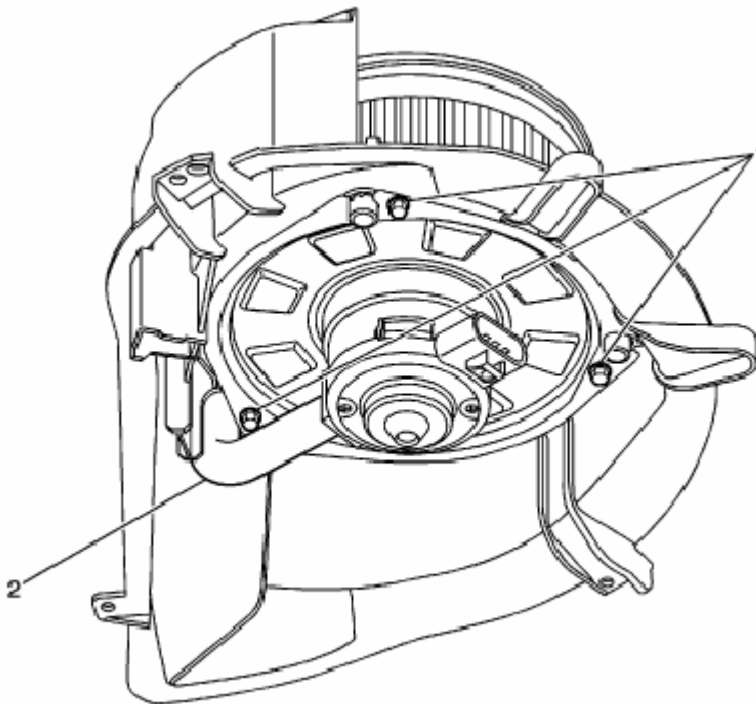

The recommended repair for this symptom is to reposition the blower motor.

- A. Remove the right side sound insulator.
- B. Loosen the three blower motor retainer bolts. (Do not remove bolts) #1
- C. Shift motor as far as allowed toward the vent tube. #2
- D. Re-tighten the retainer bolts.
- E. Re-install right side sound insulator.