



TECH TIP

Blower Motor Installation Instructions

1994 – 1999 Cadillac DeVille, Seville, and Eldorado

This blower motor has undergone some changes in design so the installation procedures have also changed. The original motor was a two piece motor and the wheel was secured with a set screw. GM changed the design to a one piece unit with a fiberglass heat shield and the wheel is pressed on.

On some of the models you may need to remove the front cradle bolts so the engine can be rocked forward. This will help keep the valve cover from interfering with the blower motor replacement. On all models; disconnect the negative battery cable.

REMOVAL

On 1994 and 1995 models: NOTE the below removal procedures pertain to the OE blower motor that was a two piece set up.

Remove the cross tower or cross member brace. Disconnect solenoid purge valve electrical and vacuum connectors. Position components aside for access.

Remove solenoid purge valve. Remove 3 center screws and inertia plate from blower motor.

Reinstall two screws to prevent motor and housing from separating. Disconnect wiring connector from blower motor. Remove 5 blower mounting screws.

On 1994 models:

Remove MAP sensor bracket. Tilt motor in case and detach wheel. Remove blower motor.

On 1995 models:

Cut the rubber insulator at guide lines and remove metal patch plate beneath. Remove harness connector, cooling hose and mounting screws. Remove blower motor.

On the 1996, 1997, 1998, and 1999 models:

NOTICE: There is a flat side on the blower motor flange that is positioned at 11 o'clock. The electrical connector is at 2 o'clock.

In addition to the disassembly steps listed on the earlier models, disconnect the 4 ignition module electrical connectors. Disconnect number 5 and 7 spark plug wires.

Remove 3 center screws and the inertia plate. Replace two of the screws so that the motor and the housing do not separate while removing. Remove the 5 blower motor mounting screws. Turn assembly counterclockwise until the flat edge is at 6 o'clock. Remove the blower motor.

TECH TIP

INSTALLATION

All models:

NOTICE: The new blower motor (35121) matches OE second design. See Fig. 2.

If present, remove the 2 ribs located on the rubber barrier.

Insert the new single piece motor with the wiring harness at the 6 o'clock position. Turn the assembly clockwise until the wiring harness is at the 11 o'clock position. Install the fiberglass heat shield with the 3 blower motor mounting screws indicated in Fig. 2. Replace all of the disassembled parts in reverse order. Be sure that spark plug wires remain at least one inch from the blower motor. Blower motor and or the ignition could fail if the spark plug wires are too close. Test for operation. If any whining or rubbing noise is heard, loosen mounting screws and reposition motor. Tighten screws to 35 inch pounds.

Fig. 1

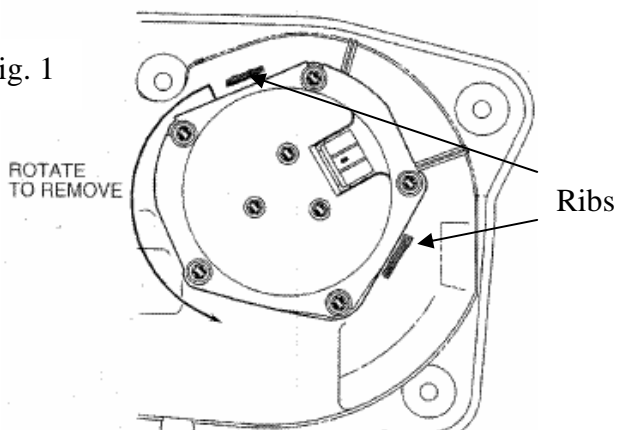

Fig. 2

