

TECH TIP

ELECTRONICALLY CONTROLLED HEATER VALVES

On some 2002 and later Ford Motor Company vehicles with Automatic Temperature Control, coolant flow to each half of the heater core is controlled by a dual coolant control valve. This valve is controlled by two electric solenoids that are individually activated by the Dual Automatic Temperature Control (DATC) Module. By individually controlling the coolant that enters each half of the heater core, driver and passenger temperature settings are maintained. Under certain settings and conditions the DATC can bypass the heater core by closing both solenoids and routing the coolant back to the engine.

Heat control diagnosis should begin with the same routine as in the past. Assure that the system is filled with the proper coolant and is free from air. Check pressure cap and engine thermostat operation. Check temperature of the heater inlet and outlet hose as well as the dual coolant control valve hoses.

If your diagnosis leads you to the dual coolant control valve, you should follow O.E. instructions for the vehicle you are working on. Using a proper jumper harness (Ford does not recommend that you back-probe the sealed connectors nor pin pierce the wires) you will be checking the resistance of the solenoids and the voltage at various pins.

Typical dual coolant control valve

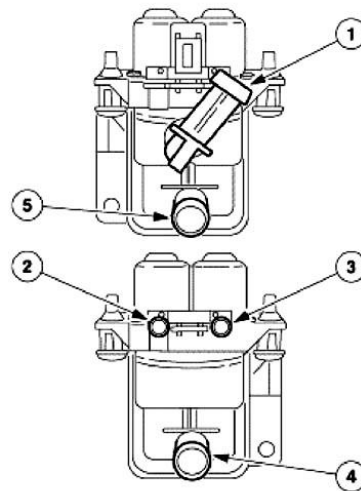

Port	Function	Location
1	Inlet—coolant from engine	front face
2	Outlet to heater core, driver side	rear face
3	Outlet to heater core, passenger side	rear face
4	Return coolant from heater core	rear face
5	Outlet—return to engine	front face

G03423041